

Stainless Steel- Multiple-joint hinges

concealed, opening angle 120°

SPECIFICATION

Types

- Type **L**: Fixing angle piece, left
- Type **R**: Fixing angle piece, right

Stainless Steel 304 **NI**
matte, ground **MT**

Friction bearing
Bronze
self lubricated



INFORMATION

Stainless Steel-Multiple-joint hinges GN 7233 are installed on the inside of flaps, hatches and doors to save space and ensure protection against vandalism. The hinges have a maximum opening angle of 120°, allowing for easy accessibility and making them suitable for use with medium-thick doors.

Use of this hinge type leaves housing exteriors free of attachments that do not match the design or that should be avoided entirely in the interests of fast and easy cleaning.

Stainless Steel-Multiple-joint hinges are generally used in pairs, meaning that one L type and one R type are used per opening. For higher loads, e.g. from large flaps or hatches, these can be supplemented with additional hinges of any type.

TECHNICAL INFORMATION

- Stainless Steel characteristics (see page A26)

ON REQUEST

- other materials
- other finishes
- other fixing angle pieces
- other opening angles
- other max. wall thicknesses
- other lifting motion

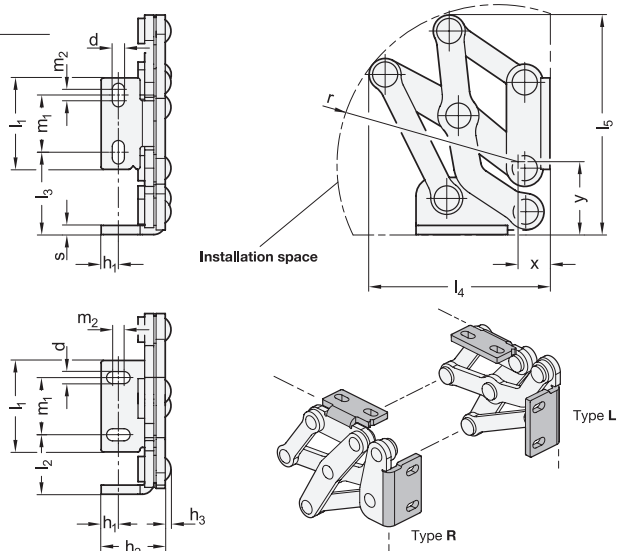

GN 7233-L

STAINLESS STEEL

Description	l1	d	h1	h2	h3	l2	l3	l4	l5	l6	l7	l8	l9	m1	m2	r	s	x	y	△
GN 7233-NI-40-L-MT	40	5.3	7.5	28	2.5	26	36	79	96	33.8	65.9	27.9	77.4	25	5	70	4	23	30.5	267
GN 7233-NI-50-L-MT	50	6.5	10	35	2.5	35	46	105	135	79.3	82	2.8	113.3	30	6	105	5	20	37	533
GN 7233-NI-60-L-MT	60	8.5	12.5	40	2.5	40	61	130	169	87.5	107.5	17.4	147.1	36	8	125	5	34	50	700

GN 7233-R

STAINLESS STEEL

Description	l1	d	h1	h2	h3	l2	l3	l4	l5	l6	l7	l8	l9	m1	m2	r	s	x	y	△
GN 7233-NI-40-R-MT	40	5.3	7.5	28	2.5	26	36	79	96	33.8	65.9	27.9	77.4	25	5	70	4	23	30.5	267
GN 7233-NI-50-R-MT	50	6.5	10	35	2.5	35	46	105	135	79.3	82	2.8	113.3	30	6	105	5	20	37	533
GN 7233-NI-60-R-MT	60	8.5	12.5	40	2.5	40	61	130	169	87.5	107.5	17.4	147.1	36	8	125	5	34	50	700

Design variants

Flaps, hatches and doors can be inset, flush or mitered. The maximum wall thicknesses and bend sizes for sheet metal constructions given below arise from the respective installation type.

1. Fixing angle pieces mounted to the housing with slots perpendicular to the hinge axis:

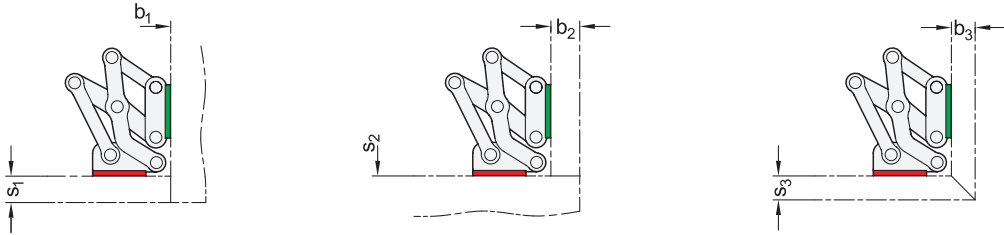

l1	s1 max.	b1	s2 max.	b2 max.	s3 max.	b3 max.
40	20	1 ... ∞	1 ... ∞	22	18	18
50	25	1 ... ∞	1 ... ∞	38	30	30
60	32	1 ... ∞	1 ... ∞	50	40	40

2. Fixing angle pieces mounted to the housing with slots parallel to the hinge axis:

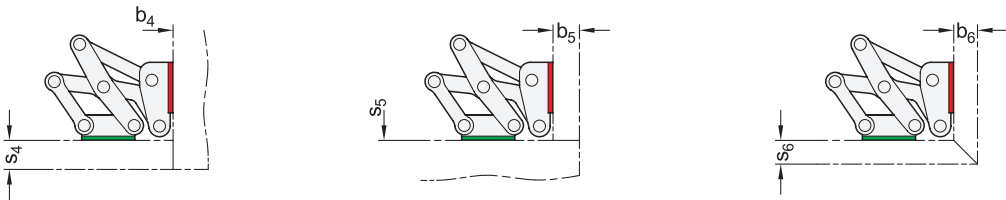

l1	s4 max.	b4 max.	s5	b5 max.	s6 max.	b6 max.
40	22	1 ... ∞	1 ... ∞	20	18	18
50	38	1 ... ∞	1 ... ∞	25	30	30
60	50	1 ... ∞	1 ... ∞	32	40	40

The design variants shown represent standard installation conditions. If the installation position of the hinge is changed or one of the two wall thickness dimensions is lower than s or b, the maximum achievable dimensions change independently of each other. This makes it possible in some cases to work with larger wall thickness dimensions than those specified with the same hinge size. A simple design check via CAD or a test setup is therefore recommended.

